

Henderson

MARK III

Utility-sized Dump Body for Unsurpassed Versatility

The Henderson **MARK III** is living proof that you don't need to sacrifice rugged, heavy-duty service just because you don't need a behemoth dump truck. It is designed for the customer who needs a utility-sized body.

It has the same rugged features as its bigger relatives. Features like: unibody design with a one-piece floor joined by a radius to the sides with a continuous weld, cross-memberless under-structure to prevent washboarding; exclusive trunnion-mounted telescopic hoist for enormous lifting power, shorter cycle time and reduction of sway; double-walled tailgate and a 9" mounting height for a lower center of gravity and increased stability.

But that is not all. The **MARK III** is styled to look better longer through outward sloped rails that shed dirt and debris. All welds are continuous seams to add rigidity and to prevent water infiltration. And much more from...

The Dependable Ones™



- Head sheet has two built-in windows to provide a better view for backing up or checking on a load while protecting the cab widow.
- Cab shield is an integral part of the head sheet and has streamlined end plates to eliminate sharp edges.
- The nitrided, trunnion-mounted telescopic hoist provides superior lift capacity and faster cycle time
- Quick-release handles on the sides give you instant side release from a single point-of-use. Latch is positive cam-action **OPTIONAL** on the tailgate.
- Includes electric gear pump with reservoir, hydraulic plumbing, electric push-button hoist control and mounting hardware.
- Five-inch structural I-beam longitudinals provide support instead of the traditional cross-members known to cause wash boarding problems.
- One-piece, double-walled fixed side panels with boxed top rail strengthen the body to prevent it from twisting. Panels stay better looking longer. Rail edges have a soft contour to resist paint chipping.
- All top rails and rub rails slope outward to shed debris.
- Unibody design features a 3/16", one-piece, seamless floor with formed 2" floor-to-side radius. The low 9" mounting height increases stability and accessibility.
- Full-depth rear corner posts tied to 5" structural channel rear apron.
- Stop/turn/tail light mounted in reach rear corner post with side clearance light and reflectors.
- Double-walled, double-acting tailgate with full perimeter boxing. Flame-cut latches are mounted to reinforce plates that overlap the rear corner post and apron to prevent spreading of sides.
- Shock resistant stop/turn/tail lights and I.C.C. light cluster are provided with a one-piece sealed wiring harness.
- The rear hinge assembly built tough to resist twisting. 1-1/4" diameter pins connect through 4" hinge bushings.
- Premium hoist control for electric/hydraulic power unit. Shock-resistant case affords long life.

UTILITY DUMP BODIES

MARK III DIMENSIONS AND CAPACITY CHART

WIDTH			HEIGHT			CAPACITY			HOIST			
LENGTH	INSIDE	OUTSIDE	SIDES	TAILGATE	HEAD	APPROX. WEIGHT (lbs)	SIDES/ENDS (cu. yd.)	w/SIDEBOARDS (cu. yd.)	TYPE CLASS	CLASS (NTEA)	NTEA RATED CAPACITY Tons @ Critical Angle	CAPACITY Tons @ Liftoff
8'	85"	95"	13"	19"	42"	1528	2.3/3.3	5.3	M-80-3.5-3	20	12.7 @ 39.1°	19.4
8'	85"	95"	18"	24"	42"	1645	3.2/4.2	5.9	M-80-3.5-3	20	12.7 @ 39.1°	19.4
9'	85"	95"	13"	19"	42"	1640	2.5/3.7	6.0	M-80-3.5-3	20	9.5 @ 34.6°	19.1
9'	85"	95"	18"	24"	42"	1753	3.5/4.7	6.5	M-80-3.5-3	20	9.5 @ 34.6°	19.1
10'	85"	95"	13"	19"	42"	1710	2.8/4.2	6.6	M-80-3.5-3	20	7.3 @ 29.8°	18.9
10'	85"	95"	18"	24"	42"	1829	3.9/5.3	7.2	M-80-3.5-3	20	7.3 @ 29.8°	18.9
11'	85"	95"	13"	19"	42"	1829	3.4/4.6	7.3	M-80-3.5-3	20	5.5 @ 33.4°	18.6
11'	85"	95"	18"	24"	42"	1933	4.3/5.8	7.9	M-80-3.5-3	20	5.5 @ 33.4°	18.6

UNIBODY DESIGN

One-piece floor with 2" formed radius to join sides. Full-depth rear corner posts tied to 5" structural channel rear apron. Smooth under structure has 5" structural steel I-beam longitudinals with no cross-members and a low 9" mounting height.

HOIST

Three-stage telescopic, trunnion-mounted hoist with nitrided cylinder tubes. Hydraulic plumbing and electric push button hoist included. Two-year warranty.

MOUNTING

- Low 9" mounting height
- Full sub-frame cradle and rear hinge assembly built in for quick installation
- Includes premium in-cab control, electric gear pump/reservoir, and mounting hardware

FLOOR

- One-piece, 3/16" steel
- 2" formed in floor-to-side radius
- 5" x 10.0 lbs./ft I-beams longsills with no cross-members

SIDES

Double-wall, 12-gauge steel with sloped, formed top rail.

HEADSHEET

12-gauge steel with integral cab shield and two pre-punched windows. (Varying cab shield heights available to optimize fit on different brands of chassis.)

TAILGATE

- One-piece 12-gauge steel.
- Double-wall sheet with full perimeter boxing and sloped top rail.
- Flush-mount, off-set tailgate hinge plates with easy-release pins.
- 1" top and 1-1/4" bottom latch pins.
- Manual over-center tailgate release mechanism with rubber covered handle.

LIGHT PACKAGE

- Stop/turn/tail lights are mounted in rear corner post.
- I.C.C. and rear clearance lights with reflectors are also included.
- All lights are rubber mounted, shock resistant and feature one-piece sealed wiring harness.

BODY PREPARATION

- Entire body is chemically cleaned with a phosphate solution before being primed.
- Primed with high-quality primer.

OPTIONS

- Aerodynamically contoured, tapered headsheet has integral cab shield.
- Headsheet without integral cab shield
- 304 Stainless steel body construction
- One-piece, 12-gauge sloping side boards
- Quick-release, fold-down sides features sloped surface to shed debris.
- Quick-release, drop-down tailgate.
- Coal chute.
- Direct mount PTO pump.
- L.E.D. light kit
- 1st Stage Power Down Cylinder



OPTIONAL contoured, tapered headsheet is aerodynamically shaped to complement the new cab designs and increase visibility.

OPTIONAL quick-release, fold-down sides and convenience. The sturdy hinge is positioned beneath the body, out of the way of falling debris. Sloped surfaces on the sides and floor help shed debris during dumping.

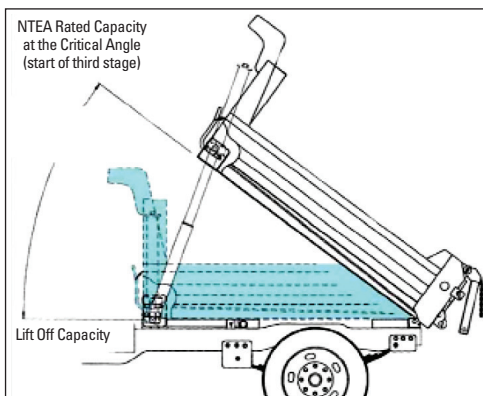

Illustrated above are the NTEA Capacity and Lift Off Capacity point of measure for the hoist.

COMPLETE MUNICIPAL SNOW & ICE CONTROL SOLUTIONS

PLOWS • WINGS • UNDERBODY SCRAPERS • SAND & SALT SPREADERS • STANDARD & PRECISION SPINNERS • DUMP BODIES • COMBINATION (MUNICIPAL) BODIES
BRINE PRODUCTION & MANAGEMENT SYSTEMS • ANTI-ICE SYSTEMS • PRE-WET SYSTEMS • SLURRY SYSTEMS • COMPLETE TURNKEY PACKAGES



© Henderson Products, Inc., A division of Douglas Dynamics, L.L.C., reserves the right in pursuit of continuous product improvement to change specifications used herein. As a **custom manufacturer** of truck bodies, truck equipment and brine systems, additional product options may be available that are not shown here.



1085 S. Third Street, Manchester, IA 52057
Toll Free: (800) 359-4970
www.HendersonProducts.com

Sourcewell CONTRACT: 080818-HPI



HP-022 05/20