



BrineXtreme FLEX

PROFESSIONAL GRADE SALT BRINE TRUCK FILLING STATION

The next generation of the industry leading BrineXtreme truck fill system has arrived. Building upon the foundation of the original BrineXtreme Truck Fill, the **BrineXtreme Flex** Truck Fill Station is a stand-alone or companion liquid transfer system for any brine production or storage facilities. As with the original BrineXtreme Truck Fill system, the **BrineXtreme Flex** Truck Fill still provides standard features such as modular design, plug-n-play installation, data logging, remote access, and password protection.

NEW EXPANDED FEATURES

- Variable flow rates from 20-200 GPM which allows liquid transfer rates to match your trucks onboard dispensing system regardless of the trucks tank(s) or plumbing sizes
- Powered off-load to transfer liquids from the truck back to storage
- Ability to stack blend to the facility storage tanks at 200 GPM
- Agitation
- Standard 2-product stack capability with an expandable option for 4 products
- New stainless steel closed coupled washdown motor to enhance longevity and removes the need for motor shimming
- An expanded user ID logging to allow for more truck users



The Dependable Ones

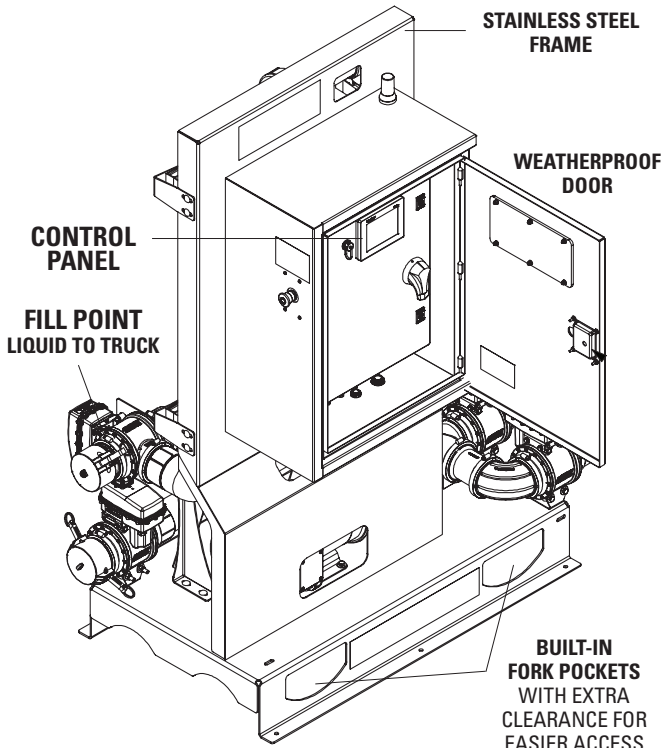

VARIABLE FLOW RATES OF 20-200 GPM

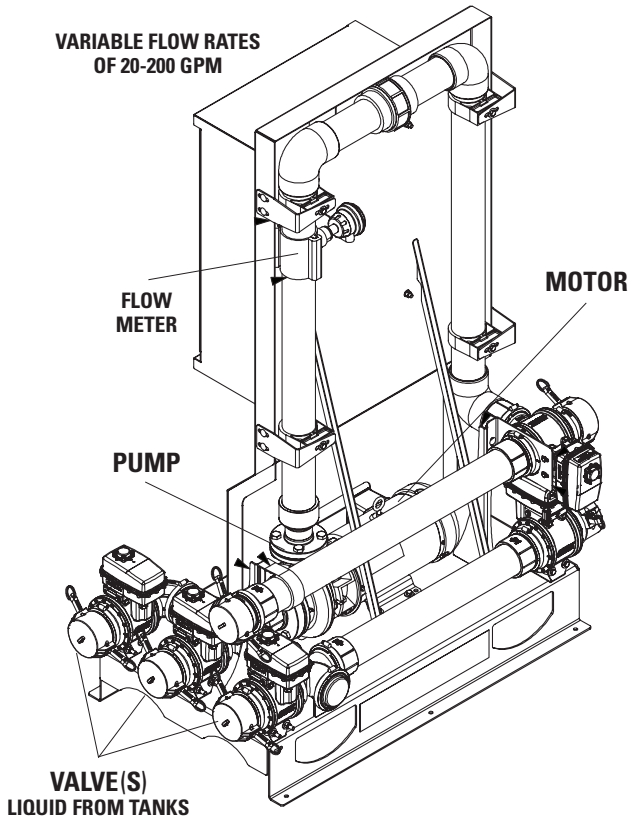

MODULAR DESIGN

A free standing truck fill station. Installs outdoors, near your liquid tanks and offers 24/7 accessibility.

PLUG-N-PLAY INSTALLATION

Fast and easy installation. Control panel setup is accomplished within minutes.

VARIABLE FLOW

20 - 200 GPM

BLEND/STACKING

Combines up to 2 or 4 products. This feature brings automated stacking capabilities to the BrineXtreme Pro controls.

MULTIPLE USERS

Through the use of unique PIN numbers, you can have up to as many as 100 different users or accounts.

DATA LOGGING

Records output: volume and mixture details into an easy to read .CSV file format. Data can be collected via LAN or USB.

REMOTE ACCESS

Provides system manager with access to data and controls via LAN, WiFi or the optional cellular gateway.

SECURE DATA

Password protection keeps your data safe and secure.

SPECIFICATIONS

DIMENSIONS: 55"W x 71"H x 35"D

SHIPPING WEIGHT: 750 lb.

FRAME CONSTRUCTION: stainless steel

MOTOR: 5 hp, SS washdown motor

PUMP: stainless steel, closed coupled

VALVES: electric, IP68

FILL RATE: Variable 20 - 200 gpm

FLOW METER: solid state magmeter

CABINET: IP66 control panel cabinet inside stainless steel cabinet with window

INPUT: LCD touch screen

CONNECTIONS: 3" cam lock

UL LISTED: yes

TRUCK OFFLOAD/AGITATION: Optional powered truck offload/agitation

COMPLETE MUNICIPAL SNOW & ICE CONTROL SOLUTIONS

PLOWS • WINGS • UNDERBODY SCRAPERS • SAND & SALT SPREADERS • STANDARD & PRECISION SPINNERS • DUMP BODIES • COMBINATION (MUNICIPAL) BODIES
BRINE PRODUCTION & MANAGEMENT SYSTEMS • ANTI-ICE SYSTEMS • PRE-WET SYSTEMS • SLURRY SYSTEMS • COMPLETE TURNKEY PACKAGES



© Henderson Products, Inc., A division of Douglas Dynamics, LLC, reserves the right in pursuit of continuous product improvement to change specifications used herein. As a **custom manufacturer** of truck bodies, truck equipment and brine systems, additional product options may be available that are not shown here.



1085 S. Third Street, Manchester, IA 52057
Toll Free: (800) 359-4970
www.HendersonProducts.com



CONTRACT: PS22170



CONTRACT: 031423-HPI



HP-199 03/24